

# **RELAY HUB**

Operating Manual

2022

## Table of Contents

1 Description and operation	4
1.1 Intended use of the product	4
1.2 Technical specifications	6
1.3 Scope	6
1.4 Configuration and operation	7
1.5 Marking and sealing	11
1.6 Packaging	11
2 Intended use	12
2.1 Preparation of the product for use	12
2.1.1 Safety measures when preparing the product	12
2.1.2 Rules for unpacking and inspection of the product	12
2.1.3 Assembly of the product	12
2.1.4 Product setup	14
2.2 Main malfunctions	15
3 Product maintenance	16
4 Transportation and storage	16

This operating manual for the RELAY HUB on-site hub (hereinafter referred to as “the product”) describes the product, the principle of operation, technical specifications, and other information necessary to ensure the fullest use of its technical capabilities and proper operation.

Installation, operation, and maintenance of the product should be carried out by specialists who have studied this OM in full and have been trained in the rules of assembling, installation, and operation of technical security equipment.

When performing installation, maintenance and routine repairs, the applicable safety regulations when operating electrical installations with a voltage of up to 1000 V must be observed.

The product complies with the requirements of the following technical regulations:

- “On the safety of low-voltage equipment”;
- “Electromagnetic compatibility of technical equipment”.

# **1 Description and operation**

## **1.1 Intended use of the product**

- 1.1.1 The product is intended for the construction of complex security systems of sites with the organisation of centralised or autonomous protection.
- 1.1.2 The product scans address detection devices (DDs) via the RS-485 interface and provides information about their status to separate outputs of the “open collector” type, which can be included in the signalling loops of control panels.
- 1.1.3 The product allows to control seven DDs via two independent RS-485 interface lines with a length of 1200 m (when using a UTP/FTP type cable of the fifth category).  
When using RS-485 interface repeaters, the maximum length of RS-485 lines can be increased.

The connection of two triboelectric and five microwave DDs is ensured, which can be connected to any interface line.

- 1.1.4 The product has 17 output circuits linked to specific address DDs:

a) for triboelectric DDs:

- 8 alarm circuits – four for each DD;
- two circuits for monitoring the integrity of sensitive elements (SE) – one for each DD;
- one common circuit for monitoring the opening (removal of the unit cover).

b) for microwave DDs:

- 5 alarm circuits – one for each DD;
- one common circuit for monitoring the opening (removal of the adjustment controls access door).

- 1.1.5 The product issues an “Alarm” notification by opening the “Alarm” circuits in case of detection of an intruder.

- 1.1.6 The product issues a “Malfunction” notification by opening the corresponding circuits in case of:

- breakage or short circuit of SE of the triboelectric DD (Te circuit opening);

- removal of the cover from the triboelectric DD (Tc-tr circuit opening, accompanied by opening of the Alarm and Te circuits of the corresponding DD);
- removal of the adjustment door of the microwave DD (Tc-mw circuit opening, accompanied by opening of the Alarm circuit of the corresponding DD);
- breakage or short circuit of any RS-485 line (opening of Tc, Alarm and Te circuits of all DDs connected to this line);
- breakage or short circuit of the power cable (opening of all circuits);
- disconnection or reduction of the supply voltage of the product to a voltage of  $(3.5 \pm 0.5) \text{ V}$  (opening of all circuits);

1.1.7 The product has LED indicators that display the current status:

- a) an indicator of the availability of power supply and operating mode: “Power”;
- b) indicators of information exchange with address DDs:

“A#11” ...”A#15”, “A#21”, “A#22”.

1.1.8 The product is powered from a DC source with a nominal voltage of 12V or 24V.

It is recommended to use a redundant power supply.

1.1.9 The product is designed for round-the-clock operation indoors at ambient temperatures from minus 30 °C to plus 50 °C and relative humidity up to 100 % at a temperature of +25 °C.

1.1.10 The product provides information collection via RS-485 line based on the Forteza - 485 v1.37 protocol and is compatible with the following DDs manufactured by Forteza JSC:

- TRIBO-S triboelectric detection device;
- FMC 24 Pro microwave detection device.

1.1.11 The output circuits of the product are compatible with the PC1616 control panel manufactured by DSC and similar panels of other brands.

## 1.2 Technical specifications

1.2.1 The technical specifications of the product are given in Table 1.1

Table 1.1 – Product specifications

Parameter	Value
Number of RS-485 interface lines, pcs.	2
Information transfer rate, bits/sec	57600
Number of DDs on RS-485 interface lines (total)	7
RS-485 interface line length (without repeater), m	1200
Number of output circuits	17
Parameters of output circuits: - switching of the sink current to the GND bus - maximum switched load voltage, V - maximum load current, mA	30 50
Power supply voltage, V	10...30
Current consumption, mA, max	20
Technical readiness time after power supply, sec, max	20
Overall dimensions, mm, max:	95x50x20
Weight, g, max:	40
Average service life of the product, years	8

## 1.3 Scope

1.3.1 The scope of the product delivery is shown in Table 1.2.

Table 1.2 – Scope of the product delivery

Document designation	Name and designation	Quantity
	Relay hub board	1
	FIX-CSS-8 (FIX&FASTEN) latch-equipped self-adhesive rack	4
	Packaging	1
	Passport	1

## 1.4 Configuration and operation

1.4.1 The product is made in the form of a board designed for installation in the control panel body/cabinet.

The appearance of the board is shown in Figure 1.1.

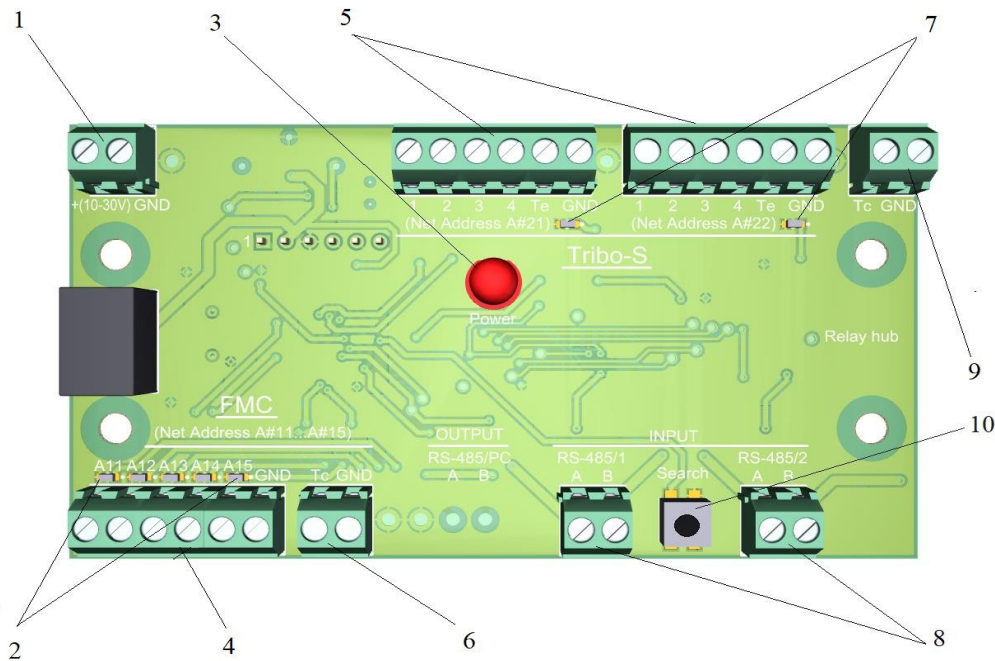

Figure 1.1 – Board appearance

The board includes:

- 1) terminals for connecting the power supply;
- 2) light indicators of the status of exchange with microwave DDs;
- 3) light indicator of the supply voltage and the “Power” operating mode;
- 4) terminals of the output circuits of microwave DDs;
- 5) terminals of the output circuits of triboelectric DDs;
- 6) terminals for monitoring the opening of microwave DDs;
- 7) light indicators of the status of exchange with triboelectric DDs;
- 8) terminals for connecting RS-485 interface lines;
- 9) terminals for monitoring the opening of triboelectric DDs;
- 10) button to switch to the mode of searching DD.

1.4.2 Four holes d3.2 mm are provided on the board for mounting.

The board is installed on the latch-equipped support racks. The racks are mounted to the body base by screws.

1.4.3 The operation principle of the product is based on the status scanning of the address DDs via two independent lines of the RS-485 interface and the issuance of notifications by opening the corresponding output circuits, in the event of the transition of the DD to an alarm state or in the event of malfunctions.

The scanning is carried out only at certain addresses A11... A15, A21 and A22. Individual output circuits are assigned to each address.

1.4.4 The product has two modes of operation: “DD search” and “Operation”.

1.4.5 Before starting the operation, the product configuration must be performed, during which the presence of DD at the specified addresses is determined and a list of DDs scanned in the “Operation” mode is created. To do this, the product is switched to the “DD search” mode.

First, the DD is scanned via the RS485/1 interface line, and then via the RS485/2 line. If a DD is detected on the RS485/1 line, no further scanning is carried out at this address in the RS485/2 line.

1.4.6 The modes of the product operation and the status of communication with the address DD are displayed by built-in LED indicators.

The “Power” indicator displays the operating mode of the product:

- disabled – there is no power supply voltage, the product is turned off;
- blinking – the product is in the “DD search” mode, the DD addresses are being searched in the RS-485 interface lines;
- lighted – there is a power supply voltage, the product is in the “Operation” mode.

The “Net Address A#21” (“A#22”) indicator displays the status of information exchange with a triboelectric DD.

In the “DD search” mode:

- disabled if there is no DD in the line (no DD detected);
- scintillating (blinking rapidly) when DD is detected.

In the “Operation” mode:



- disabled in the absence of DD (not detected during the search);
- blinking in the absence of frames received from DD (if DD was previously detected during the search);
- constantly lighted in the presence of frames received from DD.

The “Net Address A#11” (“A#12” ... “A#15”) indicator displays the status of information exchange with a microwave DD in the same way as described above.

1.4.7 Information on the status of monitored DDs is issued to the outputs of the “open collector” type. The output stage diagram is shown in Figure 1.3.

When connecting the product to the control panel, the OM instructions on the control panel regarding the selection of the connection diagram and final elements (resistors) should be followed.

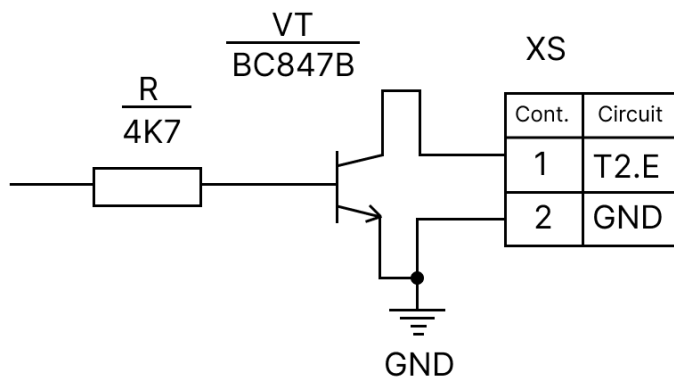

Figure 1.3 – Output stage diagram

1.4.8 The product connection layout is shown in Figure 1.4.

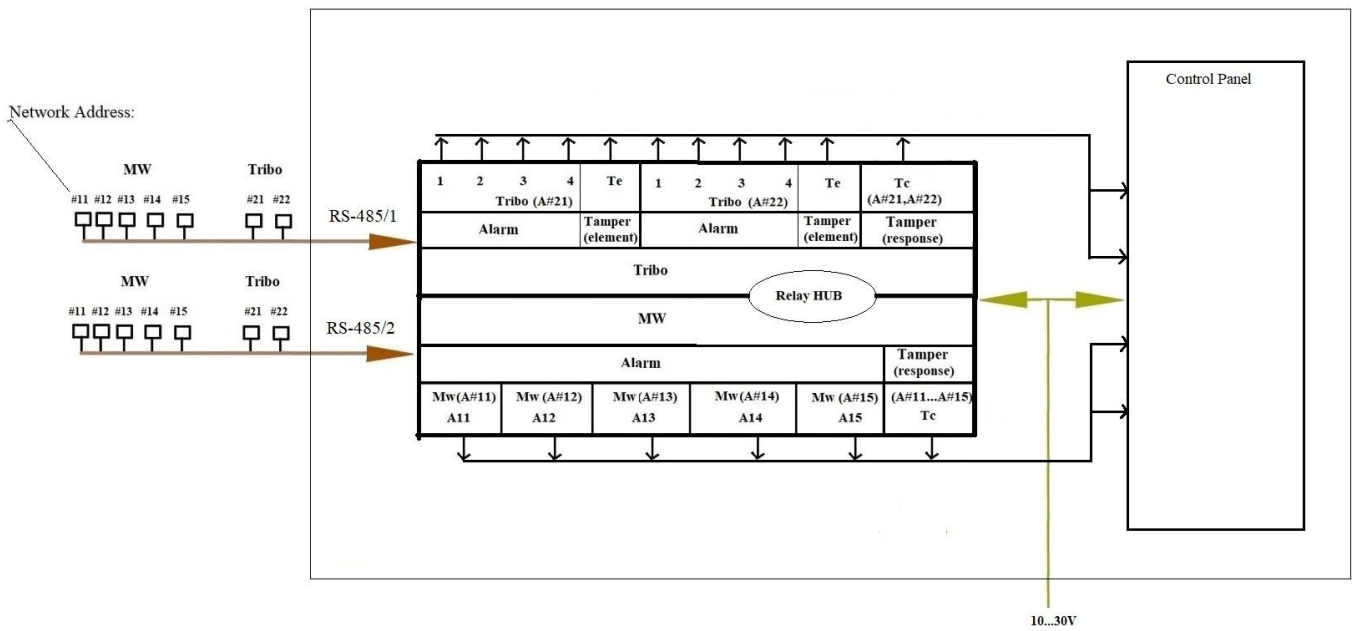

Figure 1.4 – Product connection layout

1.4.9 Options for connecting DDs are shown in Figure 1.5

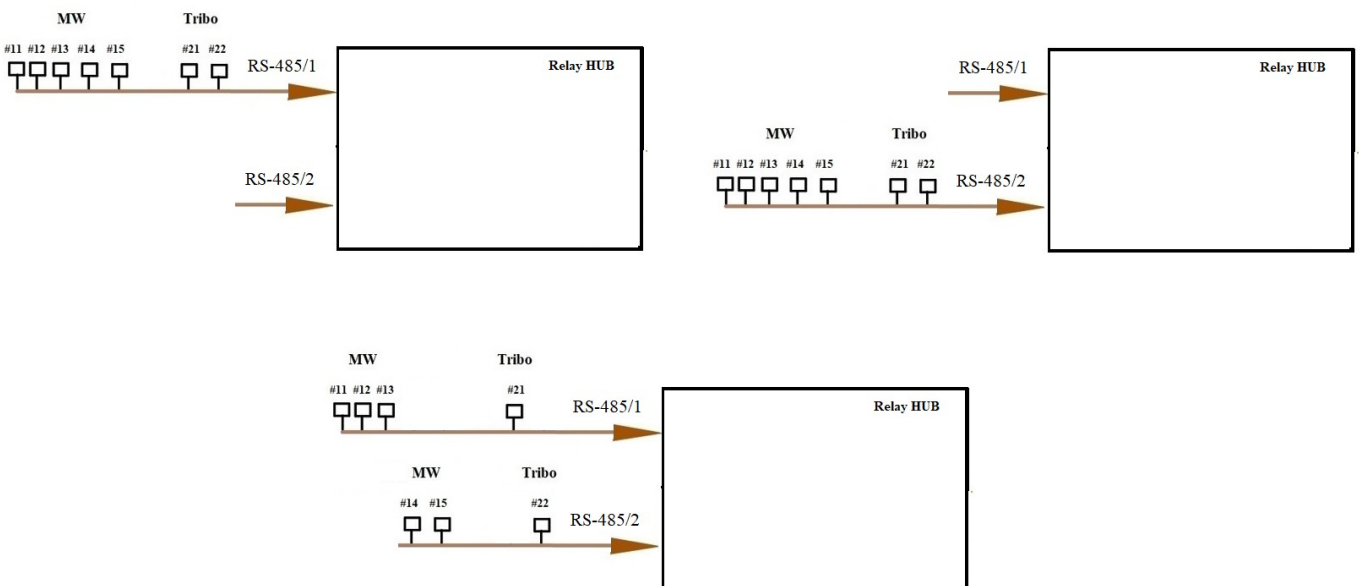

Figure 1.5 – Options for connecting DDs

## **1.5 Marking and sealing**

1.5.1 The marking of the product contains:

- the product designation;
- its factory number;
- the manufacturer's trademark;
- month and year of manufacture;
- inspection stamp.

1.5.2 The marking of consumer packaging contains:

- the product name and designation;
- the manufacturer's trademark;
- the manufacturer's name;
- month and year of packaging;
- inspection stamp.

## **1.6 Packaging**

1.6.1 A cardboard box is used as a consumer packaging. The components and operational documentation are additionally packed in plastic bags, the edges of the bags are welded.

## **2. Intended use**

### 2.1 Preparation of the product for use

#### 2.1.1 Safety measures when preparing the product

When preparing the product for use, as well as when using it, the applicable safety regulations when operating electrical installations with a voltage of up to 1000 V must be observed.

When working with the turned-on product, the unit cover must be tightly closed and locked, the key must be removed from the lock.

#### 2.1.2 Rules for unpacking and inspection of the product

Before unpacking the product, inspect the packaging and make sure of its integrity.

The package must be opened indoors or under shelter. When unpacking, exclude the ingress of atmospheric precipitation and the influence of aggressive media on the product.

Open the package and remove the components of the product.

Check the scope of the product delivery.

#### 2.1.3 Assembly of the product

##### 2.1.3.1 Installation of the product

Determine the installation location of the “Relay hub” board in the body based on the overall dimensions of the board and mount the board in the following sequence:

- mark the mounting points of the board in accordance with Figure 2.1.
- degrease the mounting points of the racks on the base of the body
- insert the racks into the holes of the board
- remove the protective coating
- press the racks firmly against the base of the body

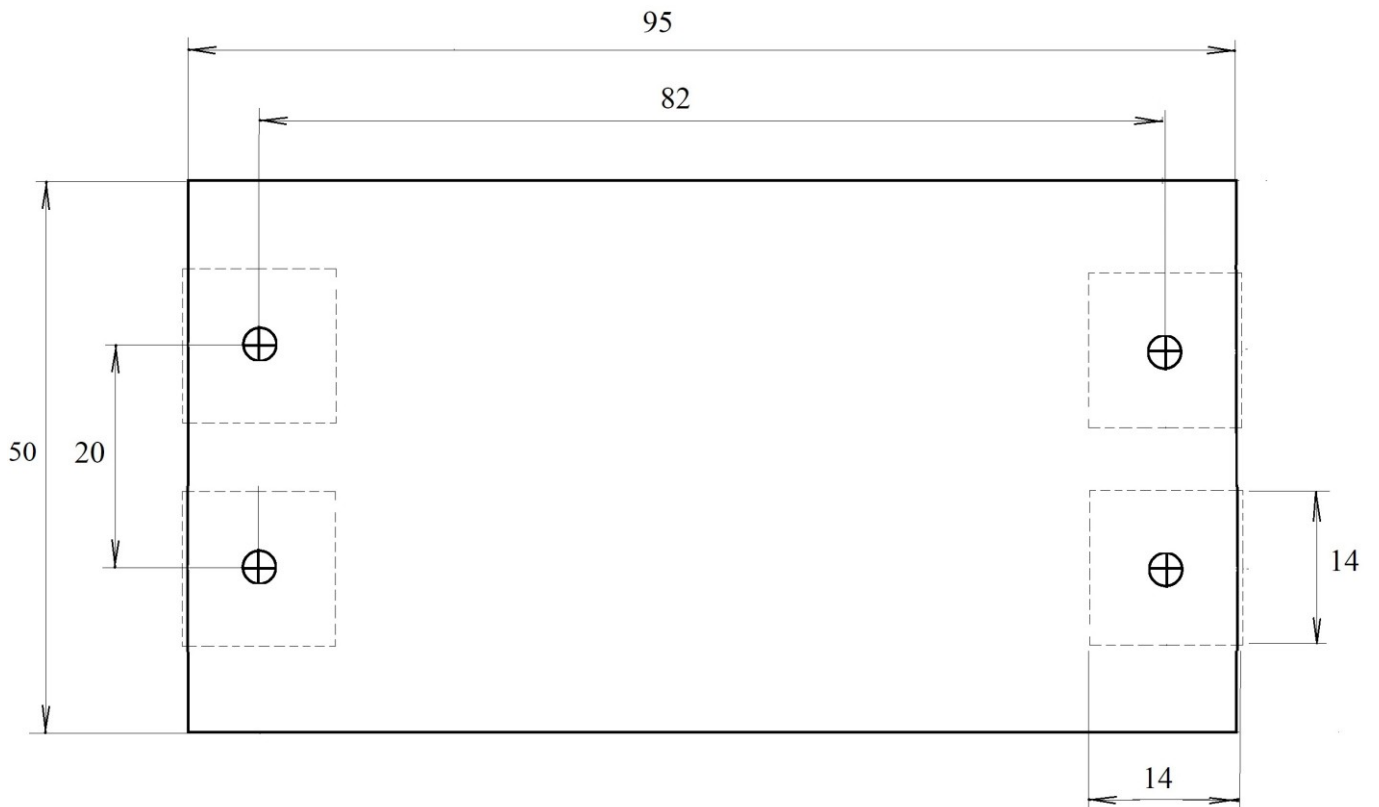

Figure 2.1 – Mounting markings

### 2.1.3.2 Connection of the product

To connect the product, it is necessary to connect the cables to the pads of the board in accordance with Table 2.1.

The intended use of the connector block contacts is given in Table 2.1.

Table 2.1 – Intended use of the connector block contacts

Contact	Marking		Intended use
1		+(10-30)V	“Power supply plus” input
2		GND	“Power supply minus” input
3	Tribo-S Net Address A#21	1	“SE1 Alarm” output
4		2	“SE2 Alarm” output
5		3	“SE3 Alarm” output
6		4	“SE4 Alarm” output
7		Te	“SE1...SE4 Malfunction” output
8		GND	common wire
9		Tribo-S Net Address A#22	1
10	2		“SE2 Alarm” output
11	3		“SE3 Alarm” output
12	4		“SE4 Alarm” output
13	Te		“SE1...SE4 Malfunction” output
14	GND		common wire
15			Tc
16		GND	common wire
17	FMC Net Address A#11... A#15	A11	“FMC Alarm A#11” output
18		A12	“FMC Alarm A#12” output
19		A13	“FMC Alarm A#13” output
20		A14	“FMC Alarm A#14” output
21		A15	“FMC Alarm A#15” output
22		GND	common wire
23		Tc	“FMC A#11... A#15 Opening” output
24		GND	common wire
25	INPUT	A	A RS485/1 line
26	RS-485/1	B	line B RS485/1
27	INPUT	A	A RS485/2 line
28	RS-485/2	B	line B RS485/2

## 2.1.4 Product setup

2.1.4.1 Connect the power supply, interface lines and control panel inputs to the terminals of the board.

The DDs must be connected to the interface lines and prepared for operation.

The DDs must have network addresses from the range A11...A15, A21, A22.

The body (door) opening contacts must be included in the break of line A of the RS-485 interface.

2.1.4.2 Supply power to the board. The “Power” indicator should light up, which indicates

the presence of power.

2.1.4.3 Press and hold the “Search” button. The “Power” indicator should be blinking. The product will switch to the DD search mode and will perform a scanning via the RS485 interface lines. When DD is detected, the corresponding “Net Address” indicators will start scintillating.

2.1.4.4 After detecting all connected DDs, release the “Search” button. The “Power” indicator should light up. The product will switch to the “Operation” mode and will scan previously detected DDs via RS485 interface lines. If there is a connection with the DD, the corresponding “Net Address” indicators will be constantly lighted.

2.1.4.5 On the control panel, check the status of the connected DDs: “Normal” in the absence of impacts and “Alarm” when performing control crossings of protected boundaries.

2.1.4.6 Tactics and rules of use of the product are established by the operating instructions.

## 2.2 Main malfunctions and ways to eliminate them

2.2.1 The main malfunctions, ways to find and eliminate them are given in Table 2.2

Table 2.2 – Main malfunctions, ways to find and eliminate them

Name and external manifestations of the malfunction	Probable cause and way to eliminate
1 When the power supply is turned on, the “Power” indicator is turned off	1 Check the mains voltage. 2 Check the reliability of the connection of the power supply plug and the wires to the connector blocks. Eliminate the detected malfunctions.
2 After the power supply to the product, the “A#11”... “A#22” indicators are not lighted	1 Check the reliability of the interface line connection on both flanks, eliminate the detected malfunctions. 2 Re-search DDs
3 Output circuits are permanently open	1 Check the reliability of the connection of the interface line to the connector blocks 2 Check the reliability of the connection of the DDs to the interface line 3 Check the reliability of the power connection, eliminate the detected malfunctions

### **3 Product maintenance**

3.1 During operation, it is recommended to carry out periodically, at least once every three months, the following monitoring, and preventive works:

- external inspection and cleaning of the product;
- check of the reliability of the contact connections and the board mounting;
- check of the power supply and the condition of the battery.

**ATTENTION! Maintenance of the product should be carried out when the power supply voltage is switched off.**

### **4. Transportation and storage**

- 4.1 The product can be transported by any type of closed-type transport.
- 4.2 Transportation must be carried out in the original packaging
- 4.3 In the storage room there should be no conductive dust, acid and alkali vapours, as well as gases that cause corrosion and destroy insulation.
- 4.4 Warranty 2 years.